

E-1 气缸、气缸头 Cylinder Head Cover

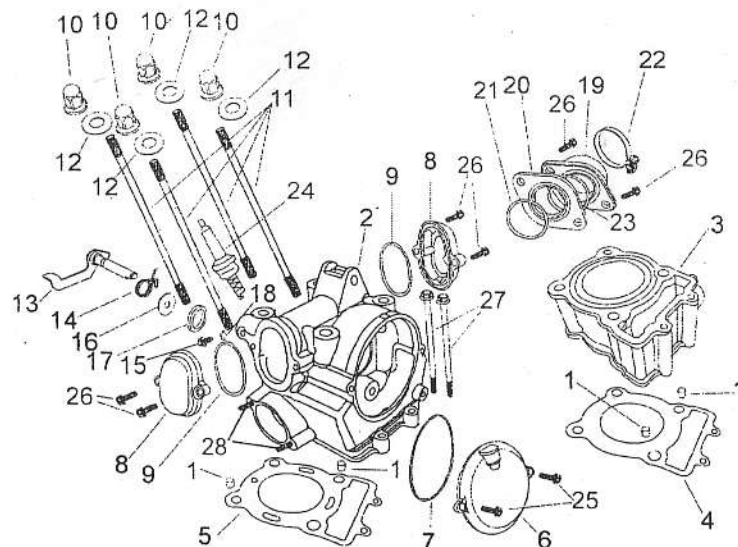

序号 S/N	零部件代号 Part No.	零部件名称	Description	数量 Quantity	备注 Remark
1	11118/172FMM	定位销 13×18	Pin, dowel, 13×18	4	
2	12210	气缸头组合	Head comp., cylinder	1	
3	12110	气缸体组合	Block, cylinder	1	
4	12121	气缸体密封垫	Gasket, cylinder block	1	
5	12220	气缸头密封垫	Gasket, cylinder head	1	
6	12242	气缸头左盖	Cover, cylinder head, LH	1	
7	12247	气缸头左盖 O 形圈 94.4×3.1	O-ring 94.4×3.1	1	
8	12253	排气门盖	Cover, exhaust valve	2	
9	12255	排气门盖 O 形圈 55.25×2.4	O-ring 55.25×2.4	2	
10	12313/172FMM	盖形螺母	Nut, cap	4	
11	12342	气缸螺栓	Stud, cylinder	4	
12	12344/172FMM	气缸螺栓钢垫圈 Φ10	Washer, steel, Φ10	4	
13	14140	减压器	Reductor	1	
14	14143	减压器弹簧	Spring, reductor	1	
15	14144	减压器螺钉	Screw, reductor	1	

E-1 气缸、气缸头 Cylinder Head Cover

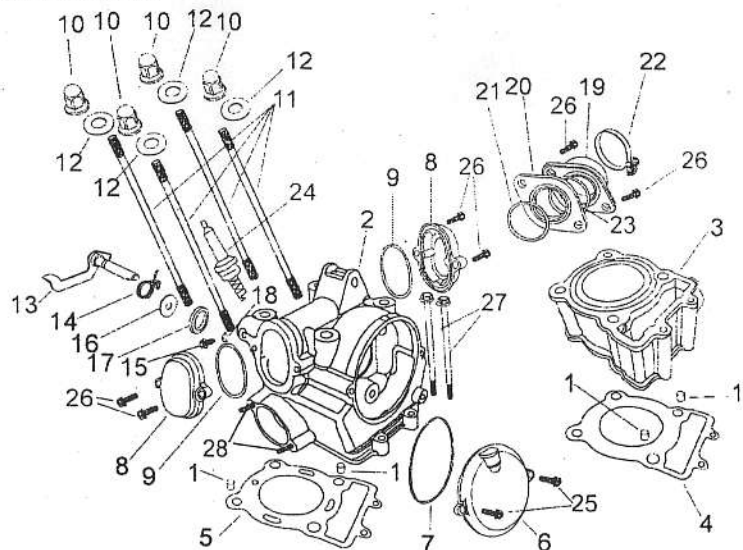

序号 S/N	零部件代号 Part No.	零部件名称	Description	数量 Quantity	备注 Remark
16	14148	操纵臂垫圈 10×20×0.5	Washer, operating arm 10×20×0.5	1	
17	14190	减压器油封 10×20×5	Oil seal, reductor 10×20×5	1	
18	14437/172FMM	铝垫 6.2×13×0.5	Washer, aluminium 6.2×13×0.5	1	
19	17310	进气管组合	Inlet pipe Assy	1	
20	17331	进气管隔热垫	Insulator, inlet pipe	1	
21	17335	隔热垫 O 形圈 31.7×2.4	O-ring, insulator 31.7×2.4	1	
22	17340	进气管卡箍	Clamp, inlet pipe	1	
23	17318	O 形圈	O-ring	1	
24	34210/156FMI-2	火花塞 D8TC	Plug, spark D8TC	1	
25	GB/T16674.1	螺钉 M6×15	Screw, M6×15	2	
26	GB/T16674.1	螺钉 M6×25	Screw, M6×25	6	
27	GB/T16674.1	螺钉 M6×105	Screw, M6×105	2	
28	GB/T899	螺柱 M6×35	Screw, M6×35	2	

E-2 凸轮轴、气门 Camshaft & Valve

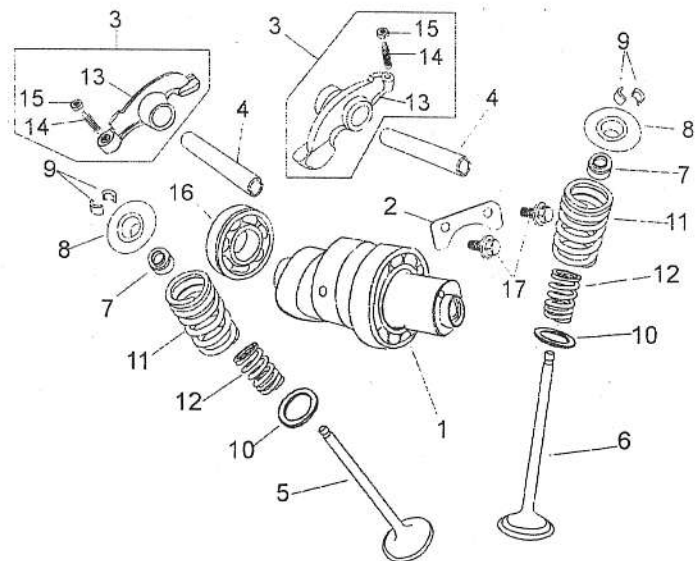

序号 S/N	零部件代号 Part No.	零部件名称	Description	数量 Quantity	备注 Remark
1	14100	凸轮装配组合	Camshaft Assy	1	
2	14322	锁紧垫	Washer, lock	1	
3	14410	摇臂装配组合	Rocker arm Assy	2	
4	14413	摇臂轴	Shaft, rocker arm	2	
5	14720	排气门	Valve, exhaust	1	
6	14710	进气门	Valve, intake	1	
7	14730/156FMI-2	挡油罩	Oil seal, valve stem	2	
8	14751	气门弹簧上座	Seat, valve spring upper	2	
9	14752	气门锁夹	Split cone, valve	4	
10	14753	气门下弹簧座	Seat, valve spring lower	2	
11	14755	气门外弹簧	Spring, valve outer	2	
12	14756	气门内弹簧	Spring, valve inner	2	
13	14411	气门摇臂	Rocker arm, valve	2	
14	14415	气门间隙调节螺钉	Adjusting screw, valve clearance	2	
15	14416	气门间隙调节螺母	Locknut	2	

E-2 凸轮轴、气门 Camshaft & Valve

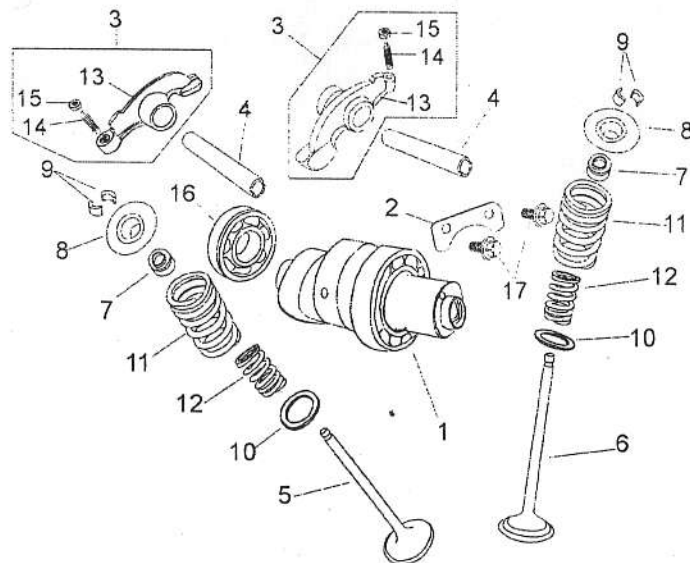

序号 S/N	零部件代号 Part No.	零部件名称	Description	数量 Quantity	备注 Remark
16	GB/T276	滚动轴承 6005	Bearing, roller, 6005	1	
17	GB/T16674.1	螺栓 M6×16	Bolt, M6×16	2	

E-3 正时链条、张紧器 Timing Chain & Tensioner

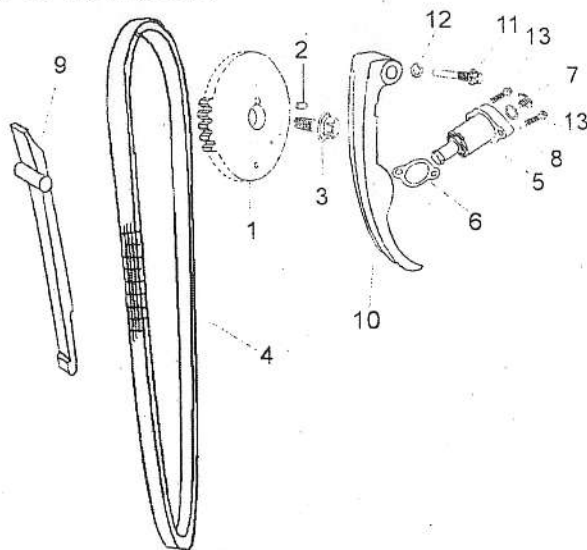

序号 S/N	零 部 件 代 号 Part No.	零 部 件 名 称	Description	数 量 Quantity	备 注 Remark
1	14221	正时从动链轮	Sprocket, timing driven	1	
2	14323	销(Φ4×10)	Pin, (Φ4×10)	1	
3	14324/2V68FMQ	正时从动链轮螺钉	Screw, sprocket, timing driven	1	
4	14350/172FMM	正时链条	Chain, timing	1	
5	14500/172FMM	张紧器总成	Tensioner Assy	1	
6	14519/172FMM	张紧器密封垫	Packing ring, tensioner	1	
7	14527/172FMM	调节孔螺钉	Screw, adjusting hole	1	
8	14528/172FMM	O型圈	O-ring	1	
9	14610/172FMM	导向板	Guiding plate	1	
10	14650	张紧板	Tensioner	1	
11	14661/172FMM	张紧板螺栓	Bolt, tensioner	1	
12	14662/172FMM	垫圈(铝垫 8.2×14.5×2)	Washer, aluminium, (8.2×14.5×2)	1	
13	GB/T16674.1	螺栓 M6×25	Bolt, M6×25	2	

E-4 右曲轴箱盖 Right crankcase Cover

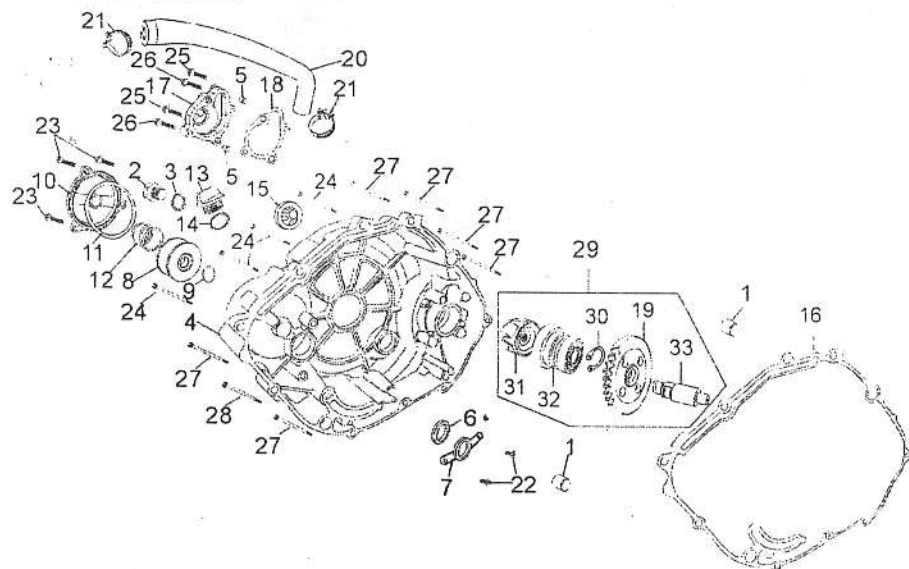

序号 S/N	零 部 件 代 号 Part No.	零 部 件 名 称	Description	数 量 Quantity	备 注 Remark
1	11118/172FMM	定位销 13×18	Pin, dowel, 13×18	2	
2	11212/172FMM	放油螺塞 M14×1.25×12	Plug, drain, M14×1.25×12	1	
3	11213/172FMM	放油螺塞垫圈 Φ14.2×20×1.2	Washer, drain plug Φ14.2×20×1.2	1	
4	11311	右曲轴箱盖	Cover, crankcase, RH	1	
5	11318/156FMI-2	定位销 8×14	Pin, dowel, 8×14	2	
6	13180/172FMM	曲轴右油封 14×26×6	Oil seal, crankshaft, RH 14×26×6	1	
7	13187/172FMM	油封压板	Plate, oil seal pressing	1	
8	15480/172FMM	机油滤芯	Element, filter	1	
9	15491/172FMM	O型圈 Φ15.8×2.4	O-ring, Φ15.8×2.4	1	
10	15492/172FMM	滤芯盖	Cover, element	1	
11	15493/172FMM	滤芯盖 O型圈 Φ72.5×2.4	O-ring, Φ72.5×2.4	1	
12	15494/172FMM	滤芯弹簧	Spring, element	1	
13	15611/172FMM	注油塞	Cap, filler	1	
14	15612/172FMM	O形圈 Φ17×3.1	O-ring, Φ17×3.1	1	
15	15620/157FMI	机油观察窗	Glass, sight	1	

E-4 右曲轴箱盖 Right crankcase Cover

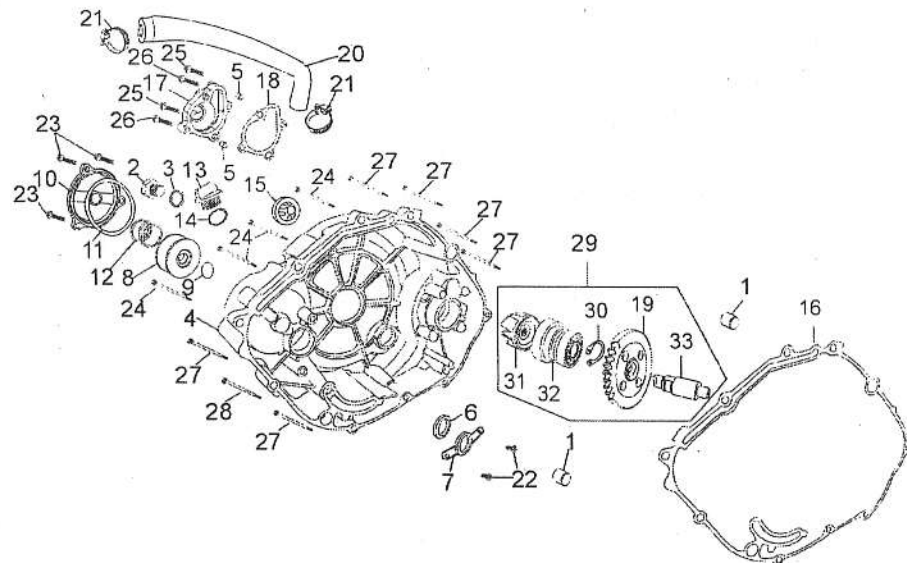

序号 S/N	零 部 件 代 号 Part No.	零 部 件 名 称	Description	数 量 Quantity	备 注 Remark
16	11319	右曲轴箱盖密封垫	Gasket, crankcase cover, RH	1	
17	19252	水泵盖	Cover, water pump	1	
18	19254	水泵密封垫	Gasket, water pump	1	
19	19270	水泵从动齿轮组合	Gear set, water pump driven	1	
20	19611	发动机水管	Pipe, engine	1	
21	19620	水管环箍组合 $\phi 25$	Clamp set, pipe, $\phi 25$	2	
22	GB/T819	螺栓 M5 \times 10	Bolt, M6 \times 10	2	
23	GB/T16674.1	螺栓 M6 \times 20	Bolt, M6 \times 20	3	
24	GB/T16674.1	螺栓 M6 \times 25	Bolt, M6 \times 25	4	
25	GB/T16674.1	螺栓 M6 \times 30	Bolt, M6 \times 30	2	
26	GB/T16674.1	螺栓 M6 \times 35	Bolt, M6 \times 35	2	
27	GB/T16674.1	螺栓 M6 \times 40	Bolt, M6 \times 40	6	
28	GB/T16674.1	螺栓 M6 \times 60	Bolt, M6 \times 60	1	
29	19200	水泵总成	Water pump Assy	1	
30	GB/T894.1	轴用弹性挡圈 A 型 $\phi 15$	Snap ring A, $\phi 15$	1	

E-4 右曲轴箱盖 Right crankcase Cover

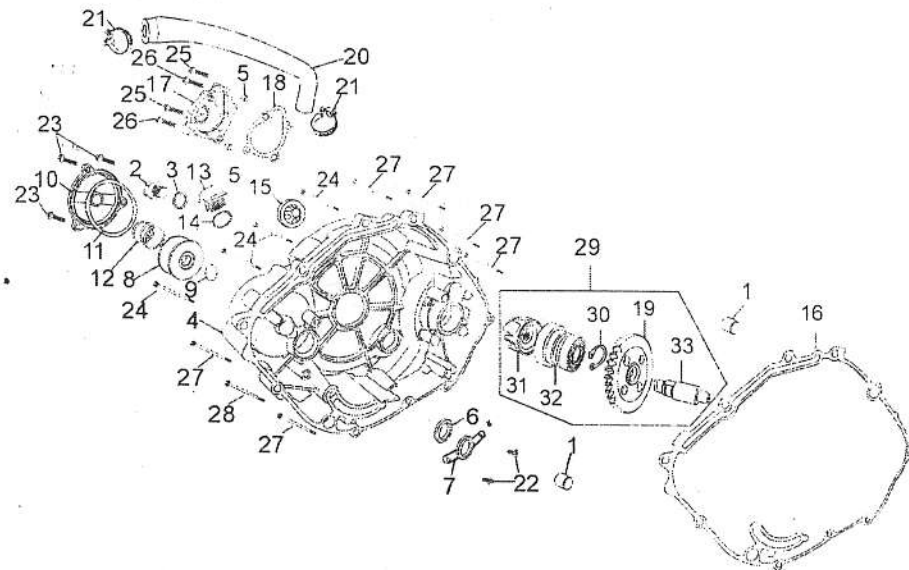

序号 S/N	零部件代号 Part No.	零部件名称	Description	数量 Quantity	备注 Remark
31	19211	叶轮	Impeller	1	
32	19251	水泵体	Body, water pump	1	
33	19253	水泵轴	Shaft, water pump	1	

E-5 曲轴箱 Crankcase

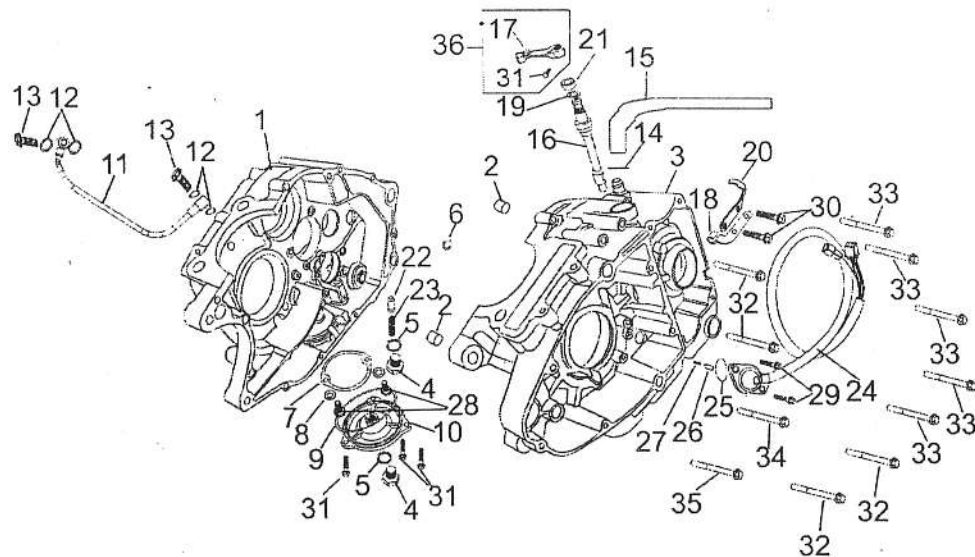

序号 S/N	零部件代号 Part No.	零部件名称	Description	数量 Quantity	备注 Remark
1	11111	右曲轴箱	Crankcase, RH	1	
2	11118/172FMM	定位销 $\phi 13 \times 18$	Pin, dowel, $\phi 13 \times 18$	2	
3	11210	左曲轴箱组合	Crankcase, comp., LH	1	
4	11212/172FMM	放油螺塞 M14 \times 1.25 \times 12	Plug, drain, M14 \times 1.25 \times 12	2	
5	11213/172FMM	放油螺塞垫圈 $\phi 14.2 \times 20 \times 1.2$	Washer, drain plug 14.2 \times 20 \times 1.2	2	
6	14427/172FMM	摇臂轴 O 形圈 $\phi 9 \times 1.9$	O-ring, $\phi 9 \times 1.9$	1	
7	15450/172FMM	机油滤网组合	Gauze set	1	
8	15459/172FMM	滤网垫圈 5.2 \times 12 \times 1	Washer, gauze 5.2 \times 12 \times 1	2	
9	15462/172FMM	机油滤网盖 O 型圈 81.5 \times 2.4	O-ring, cover gauze 81.5 \times 2.4	1	
10	15463/172FMM	机油滤网盖	Cover, gauze	1	
11	19650	进油管组合	Inlet pipe set	1	
12	19671/172FMM	油管垫圈 (铝垫 8.2 \times 14.5 \times 2)	Washer, aluminium, 8.2 \times 14.5 \times 2	4	
13	19672/172FMM	油管螺栓	Bolt, pipe	2	
14	20140/156FMI-2	废气管抱箍	Band, exhaust pipe	1	
15	20152/156FMI-2	废气管 (—)	Pipe, exhaust (I)	1	

E-5 曲轴箱 Crankcase

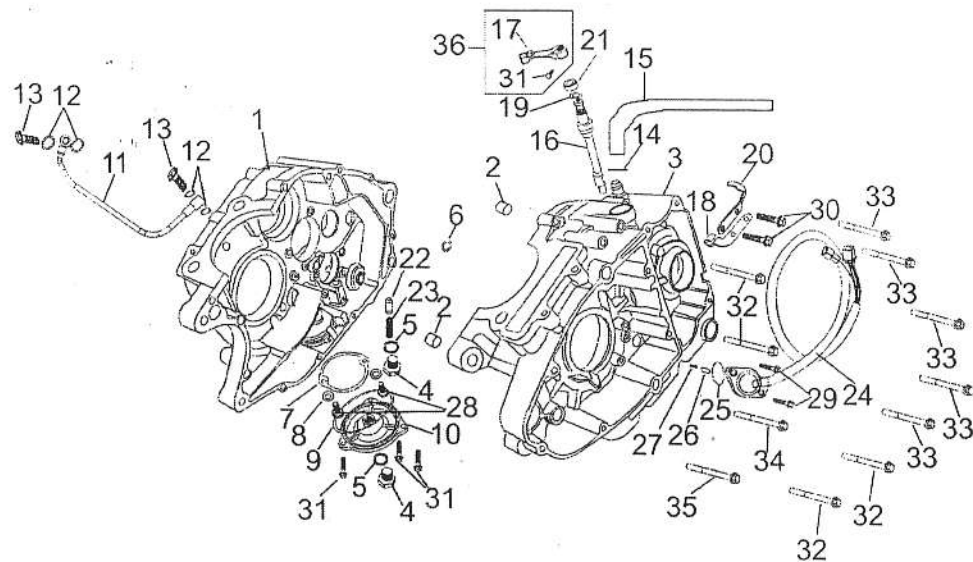

序号 S/N	零部件代号 Part No.	零部件名称	Description	数量 Quantity	备注 Remark
16	22811/172FMM	离合器操纵杆	Shaft, clutch operating	1	
17	22812/172FMM	离合器操纵臂	Arm, clutch operating	1	
18	22813/172FMM	离合器拉索支座	Holder, clutch cable	1	
19	22816/172FMM	操纵杆油封垫圈 14.0×21.8×1	Washer, 14.0×21.8×1	1	
20	22817	油封压板	Plate, oil seal pressing	1	
21	24190/172FMM	变档轴油封 12×22×9	Oil seal, gearshift shaft, 12×22×9	1	
22	24216/172FMM	变档凸轮空档定位销	Pin, gearshift drum neutral	1	
23	24217/172FMM	空档定位销弹簧	Spring, neutral pin	1	
24	35730/172FMM	档位线组合	Harness, gear wire	1	
25	35736/172FMM	O形圈Φ25.8×2.4	O-ring, Φ25.8×2.4	1	
26	35761/172FMM	档位显示销	Indicator, gear	1	
27	35762/172FMM	显示销压簧 3.5×12.5-φ0.5	Spring, 3.5×12.5-φ0.5	1	
28	GB/T5783	螺栓 M5×10	Bolt, M5×10	2	
29	GB/T5783	螺栓 M5×20	Bolt, M5×20	2	
30	GB/T16674.1	螺栓 M6×16	Bolt, M6×16	2	

E-5 曲轴箱 Crankcase

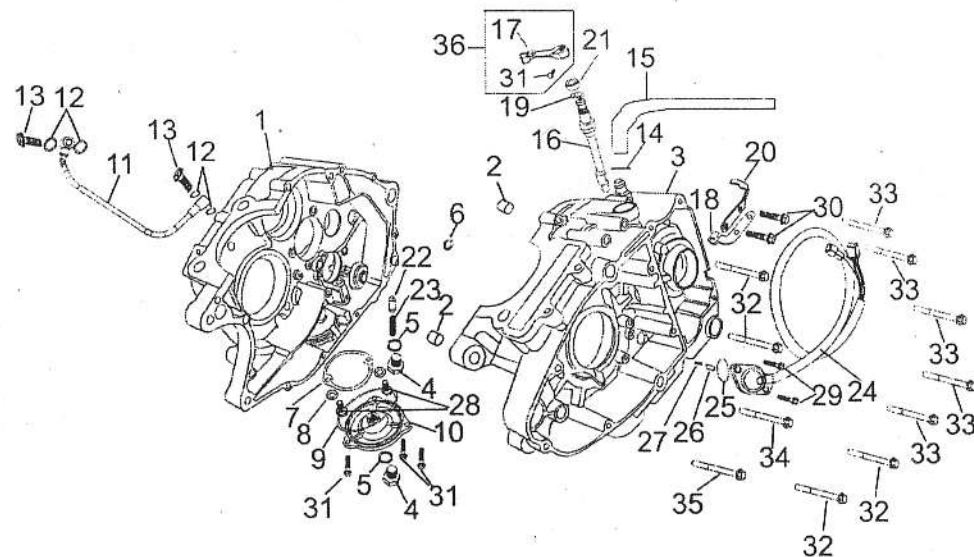

序号 S/N	零部件代号 Part No.	零部件名称	Description	数量 Quantity	备注 Remark
31	GB/T16674.1	螺栓 M6×20	Bolt, M6×20	4	
32	GB/T16674.1	螺栓 M6×35	Bolt, M6×35	4	
33	GB/T16674.1	螺栓 M6×45	Bolt, M6×45	5	
34	GB/T16674.1	螺栓 M6×55	Bolt, M6×55	1	
35	GB/T16674.1	螺栓 M6×60	Bolt, M6×60	1	
36	22801	离合器操纵臂装配组合	Arm comp., clutch operating	1	

E-6 机油泵总成 Oil pump Assy

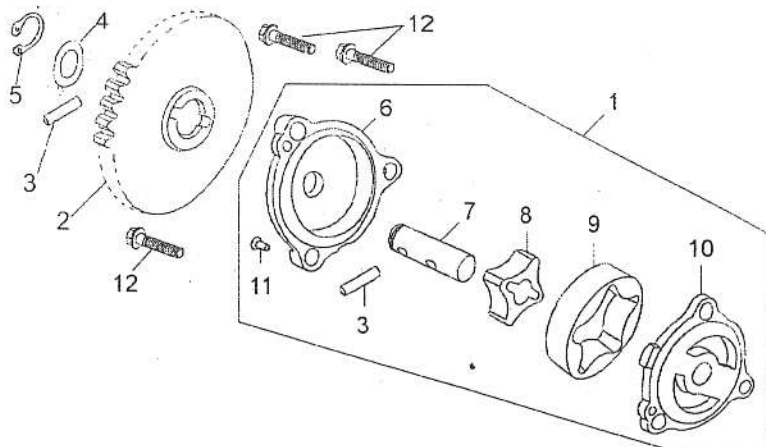

序号 S/N	零部件代号 Part No.	零部件名称	Description	数量 Quantity	备注 Remark
1	15100/172FMM	机油泵总成	Oil pump Assy	1	
2	15121	机油泵从动齿轮	Gear, oil pump driven	1	
3	15122/172FMM	圆柱销 4×15.8	Pin, cylindrical, 4×15.8	2	
4	15123/172FMM	垫圈 10.2×18×0.5	Washer, 10.2×18×0.5	1	
5	GB/T894.1	轴用弹性挡圈 A 型 Φ10	Snap ring A, Φ10	1	
6	15112	机油泵盖	Cover, oil pump	1	
7	15116	机油泵轴	Shaft, oil pump	1	
8	15114	机油泵内转子	Rotor, oil pump inner	1	
9	15115	机泵泵外转子	Rotor, oil pump outer	1	
10	15111	机油泵体	Body, oil pump	1	
11	GB/T818	螺钉 M3×8	Bolt, M3×8	1	
12	GB/T16674.1	螺栓 M6×25	Bolt, M6×25	3	

E-7 离合器 Clutch

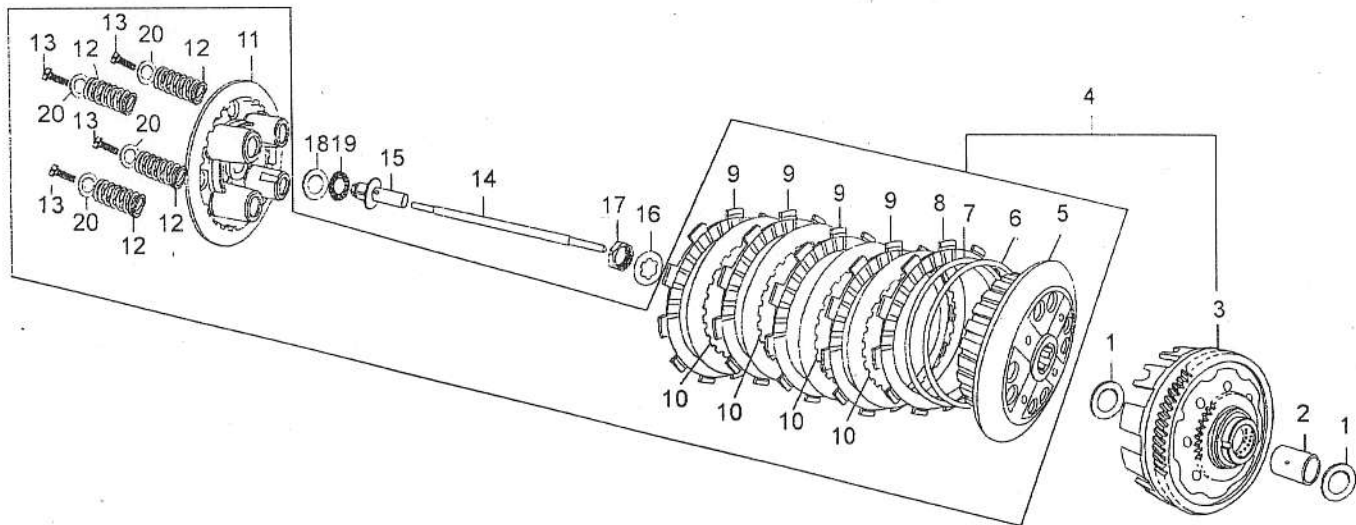

序号 S/N	零部件代号 Part No.	零部件名称	Description	数量 Quantity	备注 Remark
1	22724/172FMM	垫圈 22×36×2	Washer, 22×36×2	2	
2	22723/172FMM	轴套	Bush	1	
3	22110/172FMM	离合器主动盘组合	Drive disc set, clutch	1	
4	22100/172FMM	离合器主体组合	Body unit, clutch	1	
5	21310/172FMM	离合器从动盘组合	Driven disc set, clutch	1	
6	22343/172FMM	碟簧座圈	Retainer, disc spring	1	
7	22342/172FMM	分离碟簧	Disc spring, releasing	1	
8	22330/172FMM	离合器主动片组合 (一)	Drive plate set, clutch (I)	1	
9	22380/172FMM	离合器主动片组合 (二)	Drive plate set, clutch (II)	4	
10	22341/172FMM	从动片	Driven plate	4	
11	22351/172FMM	离合器压盘	Pressing disc set	1	
12	22371/172FMM	离合器弹簧	Spring, clutch	4	
13	GB/T5781	螺栓 M6×16	Bolt, M6×16	4	
14	22870/172FMM	离合器顶杆组合	Mandrel unit, clutch	1	
15	22860/172FMM	离合器推杆组合	Pusher unit, clutch	1	

E-7 离合器 Clutch

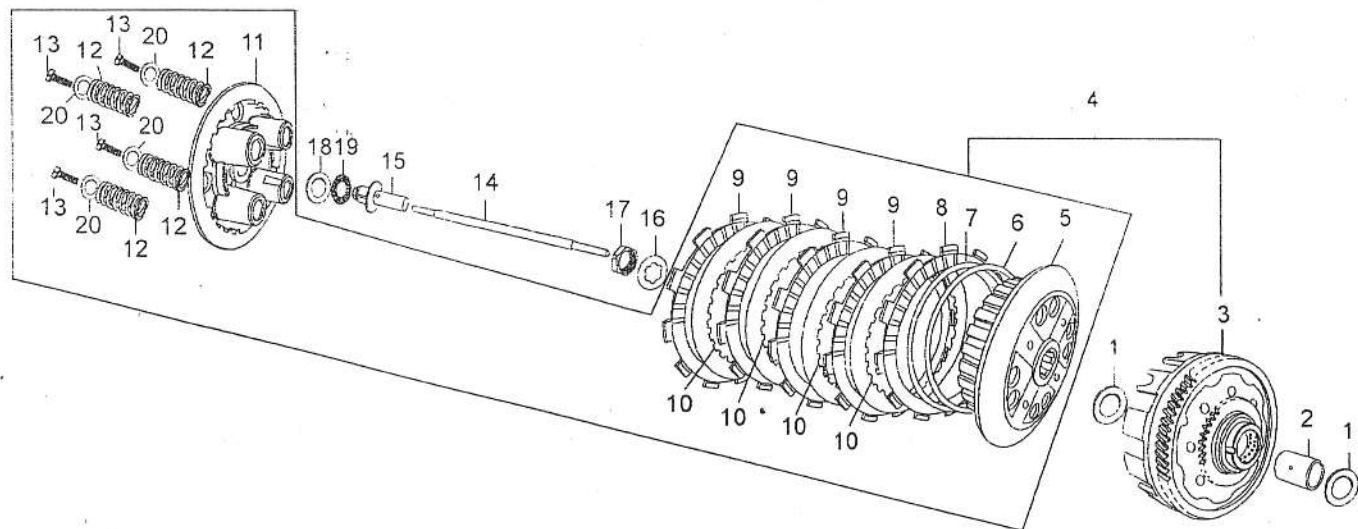

序号 S/N	零 部 件 代 号 Part No.	零 部 件 名 称	Description	数 量 Quantity	备 注 Remark
16	22152/172FMM	离合器花键垫圈	Spline washer, clutch	1	
17	22151/172FMM	离合器紧固螺母	Locknut, clutch	1	
18	22892/172FMM	垫圈 15.6×27.8×1	Washer, 15.6×27.8×1	1	
19	GB/T4605	平面轴承 15×27.8×2	Bearing, needle, 15×27.8×2	1	
20	22392	垫圈 5.3×19.6×1.5-Zn.B	Washer, 5.3×19.6×1.5-Zn.B	4	

E-8 左曲轴箱盖、磁电机、起动器组合 Left crankcase Cover, Magneto & Starter Assy

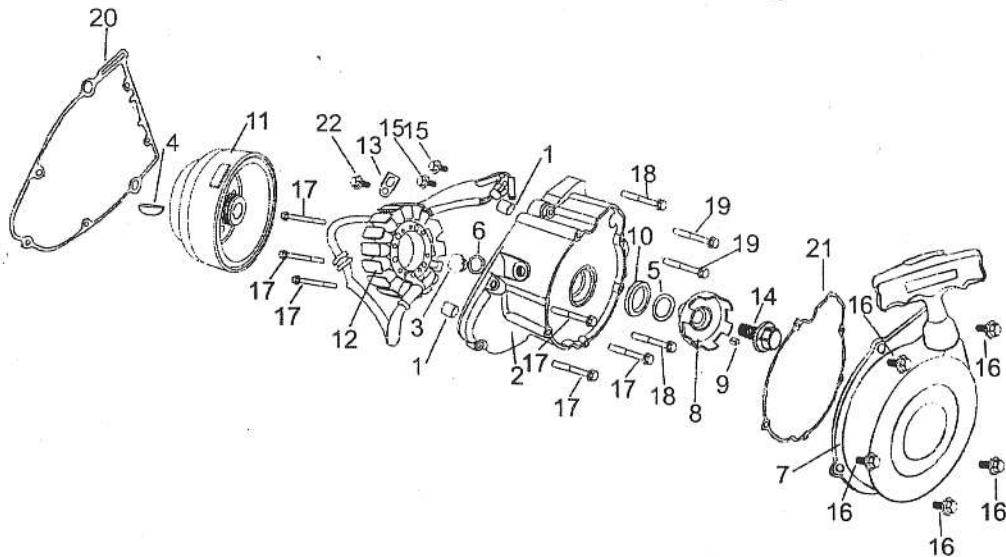

序号 S/N	零 部 件 代 号 Part No	零 部 件 名 称	Description	数 量 Quantity	备 注 Remark
1	11118/172FMM	定位销 $\phi 13 \times 18$	Pin, dowel, $\phi 13 \times 18$	2	
2	11411	左曲轴箱盖	Cover, crankcase, LH	1	
3	11412/172FMM	观察孔螺塞 $M12 \times 1.25 \times 10$	Plug, view-hole, $M12 \times 1.25 \times 10$	1	
4	13118/172FMM	半圆键	Key, woodruff	1	
5	15612/172FMM	O形圈 $\phi 17.5 \times 3.5$	O-ring, $\phi 17.5 \times 3.5$	1	
6	11413/172FMM	观察孔螺塞垫圈 $\phi 12.2 \times 16 \times 1.2$	Washer, $\phi 12.2 \times 16 \times 1.2$	1	
7	26300	起动器组合	Starter Assy	1	
8	26370	起动套组合	Sleeve, starter	1	
9	26378	起动套连接键 $3 \times 3 \times 10$	Key, $3 \times 3 \times 10$	1	
10	26390	起动套油封 $28 \times 40 \times 7$	Oil seal, $28 \times 40 \times 7$	1	
11	31102/172FMM	转子带起动离合器组合	Rotor with starting clutch	1	
12	31210/172FMM	磁电机定子组合	Stator, magneto	1	
13	31213/172FMM	压线板	Plate, pressing	1	
14	31311/2V68FMQ	磁电机紧固螺栓 $M10 \times 1.25 \times 40$	Lock bolt, magneto, $M10 \times 1.25 \times 40$	1	
15	GB/T5783	螺栓 $M5 \times 10$	Bolt, $M5 \times 10$	2	

E-8 左曲轴箱盖、磁电机、起动机组合 Left crankcase Cover, Magneto & Starter Assy

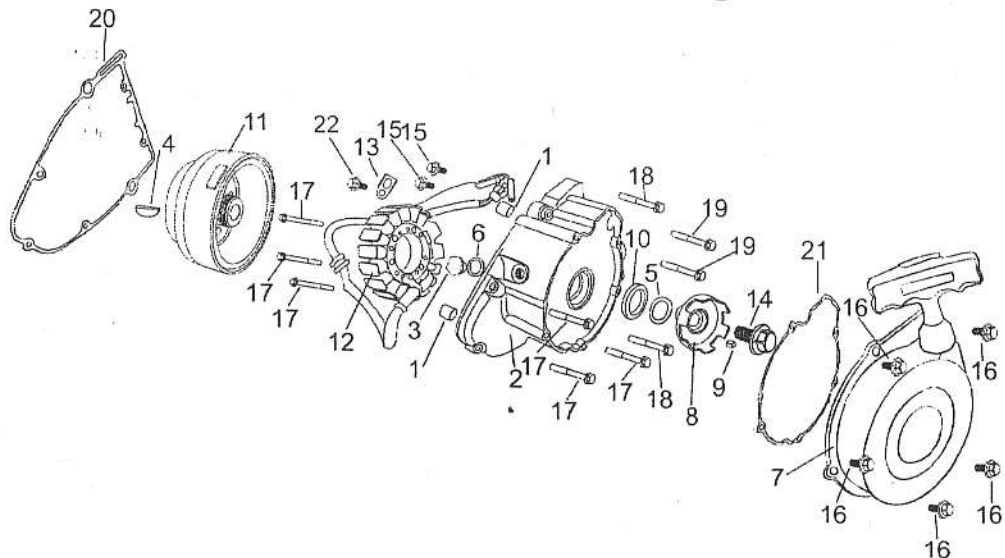

序号 S/N	零部件代号 Part No.	零部件名称	Description	数量 Quantity	备注 Remark
16	GB/T16674.1	螺栓 M6×20	Bolt, M6×20	5	
17	GB/T16674.1	螺栓 M6×25	Bolt, M6×25	6	
18	GB/T16674.1	螺栓 M6×45	Bolt, M6×45	2	
19	GB/T16674.1	螺栓 M6×65	Bolt, M6×65	2	
20	11419	左曲轴箱盖密封垫	Gasket, crankcase cover, LH	1	
21	26319	起动机密封垫	Gasket, starter	1	
22	GB/T5783	螺栓 M5×8	Bolt, M5×8	1	

E-9 曲轴、活塞、平衡轴 Crankshaft, Piston & Balanced shaft

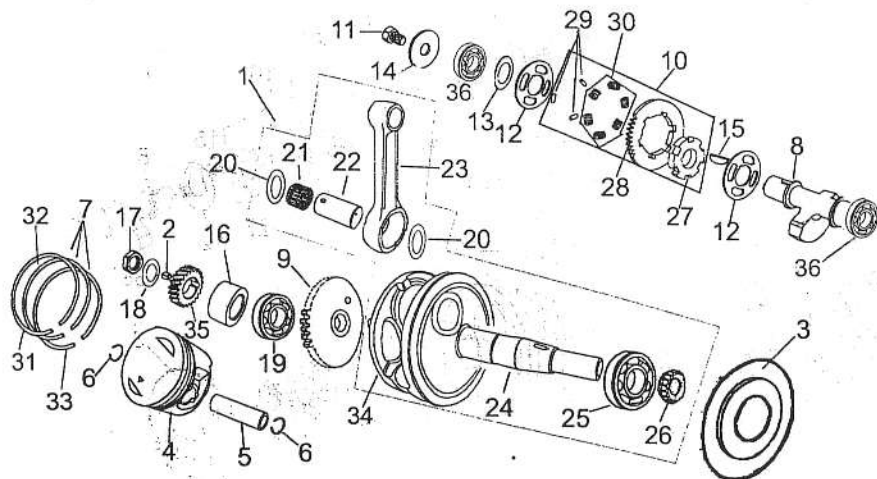

序号 S/N	零部件代号 Part No.	零部件名称	Description	数量 Quantity	备注 Remark
1	13100	曲柄连杆组合	Crank & connecting rod	1	
2	13123/172FMM	平键 12.5×7h8×7	Key, flat, 12.5×7h8×7	1	
3	13179	轴承垫板	Pad, bearing	1	
4	13211	活塞	Piston	1	
5	13221/172FMM	活塞销	Pin, piston	1	
6	13222/172FMM	活塞销挡圈	Circlip, piston pin	2	
7	13300/172FMM	活塞环组	Ring set, piston	1	
8	13611/172FMM	平衡轴	Shaft, balanced	1	
9	13631/172FMM	主动齿轮	Gear, drive	1	
10	13640/172FMM	平衡轴从动齿轮组合	Gear set, balanced shaft driven	1	
11	13651/172FMM	紧固螺栓 M12×1.25×16	Lock bolt, M12×1.25×16	1	
12	13652/172FMM	垫圈(一) 25.2×60×2	Washer (I), 25.2×60×2	2	
13	13653/172FMM	垫圈(二) 25.2×36×0.5	Washer (II), 25.2×36×0.5	1	
14	13654/172FMM	垫圈(三) 12.2×40×2.5	Washer (III), 12.2×40×2.5	1	
15	13655/172FMM	半圆键	Key, woodruff	1	

E-9 曲轴、活塞、平衡轴 Crankshaft, Piston & Balanced shaft

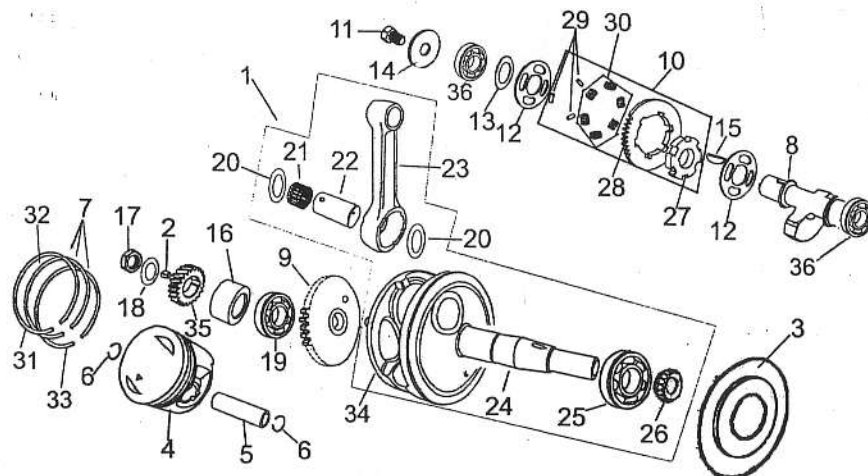

序号 S/N	零部件代号 Part No.	零部件名称	Description	数量 Quantity	备注 Remark
16	22628	主动齿轮隔套	Spacer, drive gear	1	
17	22631/172FMM	初级主动齿轮紧固螺母 (M20×1.5×8-左)	Locknut, (M20×1.5×8-L)	1	
18	22633/172FMM	碟形垫圈	Washer	1	
19	GB/T276	轴承 6306	Bearing, 6306	1	
20	13158/172FMM	垫圈 31×48.5×1	Washer, 31×48.5×1	2	
21	13150/172FMM	连杆大头轴承	Roller bearing, connecting rod big end	1	
22	13141/172FMM	曲柄销	Pin, crank	1	
23	13131/172FMM	连杆	Rod, connecting	1	
24	13111/172FMM	左曲柄	Crank, LH	1	
25	GB/T276	轴承 6307	Bearing, 6307	1	
26	14211	正时主动链轮	Sprocket, timing drive	1	
27	13647/172FMM	从动齿轮内套	Sleeve, driven gear inner	1	
28	13641/172FMM	平衡轴从动齿轮	Gear, balanced shaft driven	1	
29	13649	弹簧定位销	Pin, cowl	3	
30	13644/172FMM	弹簧	Spring	6	

E-9 曲轴、活塞、平衡轴 Crankshaft, Piston & Balanced shaft

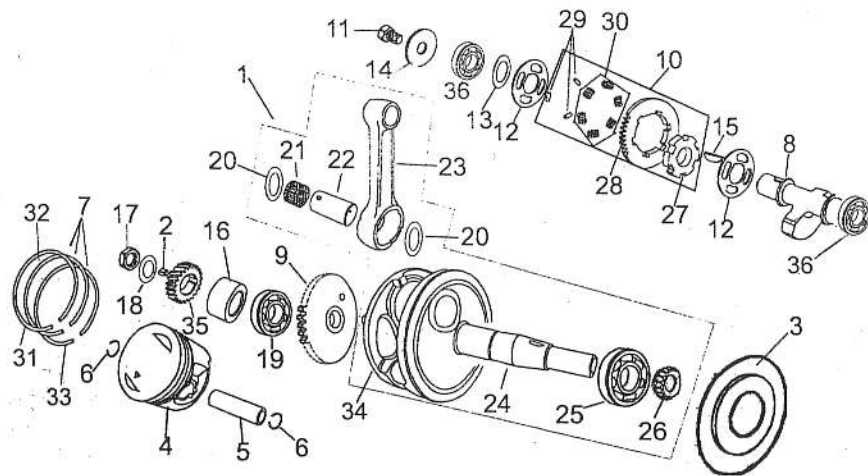

序号 S/N	零部件代号 Part No.	零部件名称	Description	数量 Quantity	备注 Remark
31	13311/172FMM	活塞环 (一)	Ring, piston (I)	1	
32	13312/172FMM	活塞环 (二)	Ring, piston (II)	1	
33	13320/172FMM	油环组合	Oil ring, 3-piece	1	
34	13121/172FMM	右曲柄	Crank, RH	1	
35	22621/172FMM	初级主动齿轮	Sprocket, primary drive	1	
36	GB/T276	轴承 6305	Bearing, 6305	2	

E-10 主、副轴 Main shaft& Countershaft

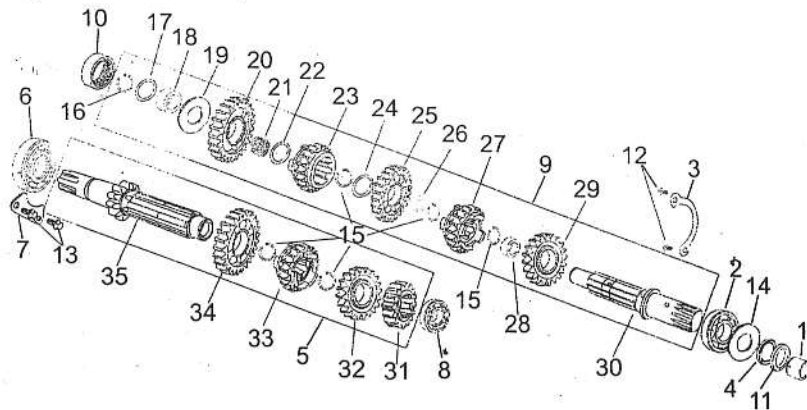

序号 S/N	零 部 件 代 号 Part No.	零 部 件 名 称	Description	数 量 Quantity	备 注 Remark
1	22716	链轮隔套	Spacer, sprocket	1	
2	23080/172FMM	副轴左轴承 (轴承 63/22 带槽)	Bearing (with a groove), countershaft, LH	1	
3	23089/172FMM	轴承挡板	Stopper, bearing	1	
4	23090/172FMM	副轴内油封 30×43×2	Oil seal, countershaft, internal	1	
5	23600/172FMM	主轴组合	Main shaft Assy	1	
6	23670/172FMM	主轴右轴承 (轴承 63/22 带销)	Bearing(with a pin), main shaft (RH)	1	
7	23679/172FMM	轴承挡板	Stopper, bearing	1	
8	23680/172FMM	主轴左轴承 (轴承 6203RZ)	Bearing, main shaft, LH	1	
9	23700	副轴组合	Countershaft comp.	1	
10	23780	副轴滚针轴承 26×36×12×R0.6 无内圈	Bearing, needle, 26×36×12×R0.6	1	
11	23790/172FMM	副轴油封 30×43×5.2	Oil seal, countershaft 30×43×5.2	1	
12	GB/T819	螺钉 M6×12	Screw, M6×12	2	
13	GB/T16674.1	螺栓 M6×12	Bolt, M6×12	2	
14	23088/172FMM	轴承垫圈 35.0×55.8×1	Washer, bearing 35.0×55.8×1	1	
15	23672/172FMM	弹性挡圈	Snap ring	5	

E-10 主、副轴 Main shaft & Countershaft

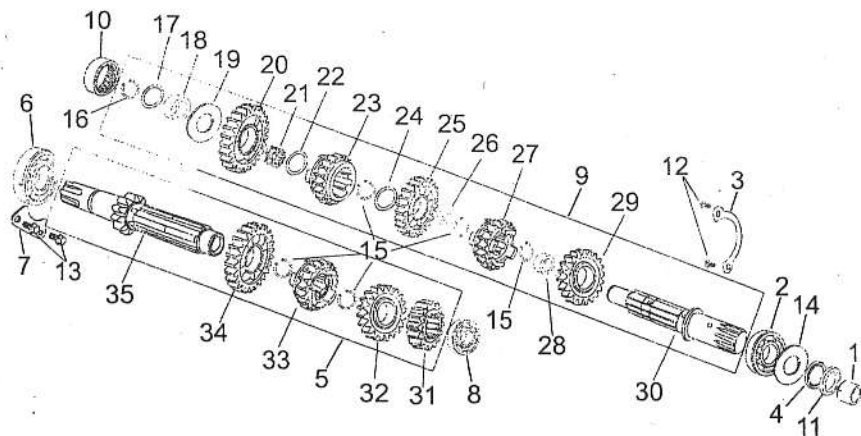

序号 S/N	零部件代号 Part No.	零部件名称	Description	数量 Quantity	备注 Remark
16	GB/T894.1	挡圈 17	Retainer 17	1	
17	23773/172FMM	垫圈 (一)	Washer (I)	1	
18	23777/172FMM	轴套	Sleeve	1	
19	23779/172FMM	垫圈 (三)	Washer (III)	1	
20	23711/172FMM	副轴一档齿轮	Gear, countershaft 1st	1	
21	23050	滚针轴承 17×21×9.8	Bearing, roller, 17×21×9.8	1	
22	23774/172FMM	垫圈 (二)	Washer (II)	1	
23	23751/172FMM	副轴五档齿轮	Gear, countershaft 5th	1	
24	23775/172FMM	内花键垫圈	Spline washer, internal	1	
25	23731/172FMM	副轴三档齿轮	Gear, countershaft 3rd	1	
26	23732/172FMM	副轴三档齿轮衬套	Bush, countershaft 3rd gear	1	
27	23741/172FMM	副轴四档齿轮	Gear, countershaft 4th	1	
28	23722/172FMM	副轴二档齿轮衬套	Bush, countershaft 2nd gear	1	
29	23721/172FMM	副轴二档齿轮	Gear, countershaft 2nd gear	1	
30	23770	副轴组件	Countershaft	1	

E-10 主、副轴 Main shaft & Countershaft

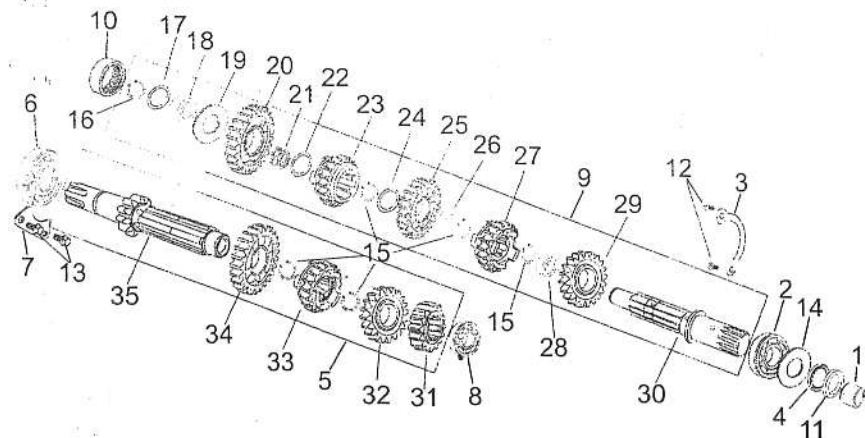

序号 S/N	零部件代号 Part No.	零部件名称	Description	数量 Quantity	备注 Remark
31	23621/172FMM	主轴二档齿轮	Gear, main shaft 2nd	1	
32	23641/172FMM	主轴四档齿轮	Gear, main shaft 4th	1	
33	23631/172FMM	主轴三档齿轮	Gear, main shaft 3rd	1	
34	23651/172FMM	主轴五档齿轮	Gear, main shaft 5th	1	
35	23610/172FMM	主轴组件	Main shaft	1	

E-11 变档机构 Drum set

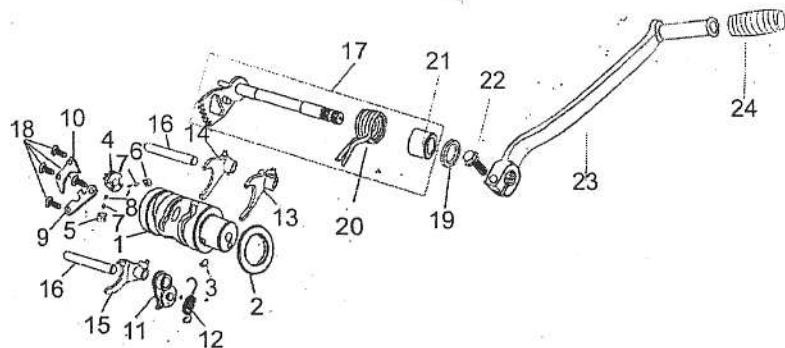

序号 S/N	零部件代号 Part No.	零部件名称	Description	数量 Quantity	备注 Remark
1	24210/172FMM	变档凸轮组合	Drum comp., gearshift	1	
2	24221/157FMI	变档轮	Wheel, gearshift	1	
3	24222/172FMM	变档轮定位销 $\phi 4 \times 6$	Set pin, gearshift wheel $\phi 4 \times 6$	1	
4	24241/157FMI	变档凸轮驱动装置	Driving device, gearshift drum	1	
5	24242/157FMI	凸轮爪片 A	Catch A	1	
6	24243/157FMI	凸轮爪片 B	Catch B	1	
7	24244/172FMM	定位销	Pin, dowel	2	
8	24245/172FMM	弹簧 $3.5 \times 10.5 - \phi 0.5$	Spring $3.5 \times 10.5 - \phi 0.5$	2	
9	24246/172FMM	凸轮控制板	Plate, drum control	1	
10	24247/172FMM	凸轮导板	Guide, drum	1	
11	24310/172FMM	档位定位板组合	Plate set, gearshift locating	1	
12	24323/172FMM	定位板弹簧	Spring, locating plate	1	
13	24411/172FMM	拨叉 (一)	Fork (I)	1	
14	24412/172FMM	拨叉 (二)	Fork (II)	1	
15	24413/172FMM	拨叉 (三)	Fork (III)	1	

E-11 变档机构 Drum set

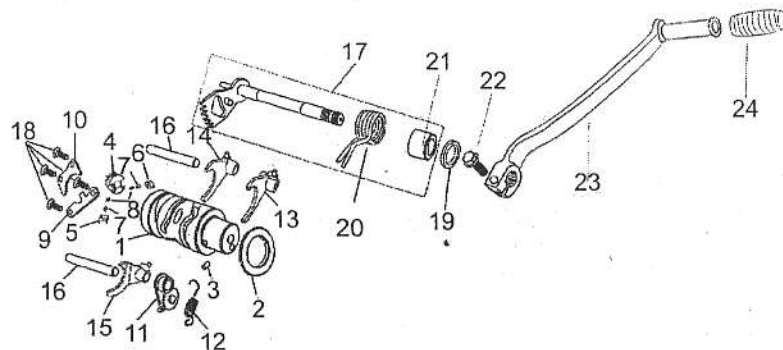

序号 S/N	零部件代号 Part No.	零部件名称	Description	数量 Quantity	备注 Remark
16	24421/172FMM	拨叉轴	Shaft, fork	2	
17	24100	变档轴总成	Shaft Assy, gearshift	1	
18	GB/T819	螺钉 M6×12	Screw, M6×12	4	
19	24190/157FMM	变档轴油封	Oil seal, gearshift shaft	1	
20	24131/172FMM	回位弹簧	Return spring	1	
21	24125/172FMM	轴套	Bush	1	
22	GB/T5781	螺栓	Bolt	1	
23	24720	变档杆焊接组合	Gearshift lever weldment	1	
24	24711	变档杆胶套	Rubber	1	

E-12 起动电机 Starting Motor

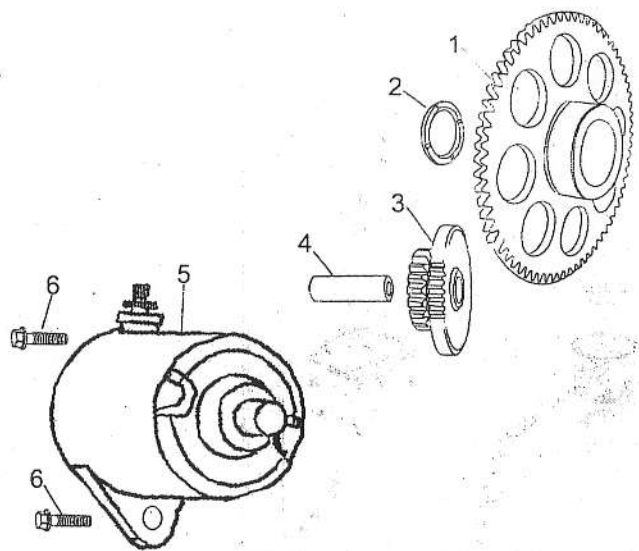

序号 S/N	零部件代号 Part No.	零部件名称	Description	数量 Quantity	备注 Remark
1	28150/172FMM	起动离合器齿轮组合	Gear set, starting clutch	1	
2	28172/172FMM	起动离合器齿轮垫圈 27.1×38×2.5	Washer, 27.1×38×2.5	1	
3	28311/172FMM	双联齿轮	Dual-gear	1	
4	28321/172FMM	双联齿轮轴	Shaft, dual-gear	1	
5	34700/172FMM	起动电机	Motor, starting	1	
6	GB/T16674.1	螺栓 M6×25	Bolt, M6×25	2	

E-13 化油器 Carburetor

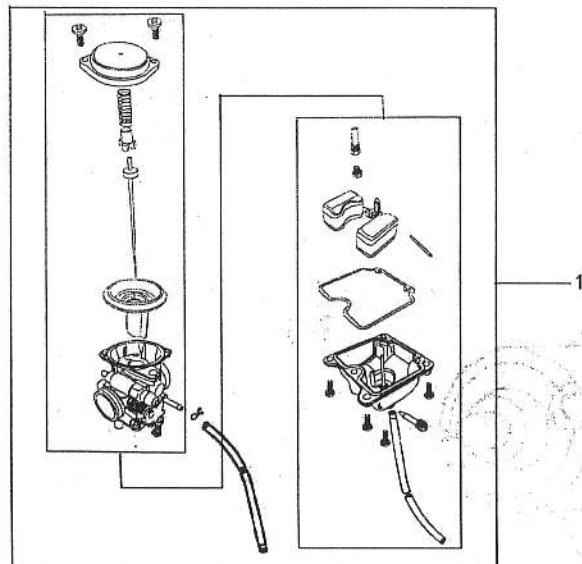

序号 S/N	零部件代号 Part No.	零部件名称	Description	数量 Quantity	备注 Remark
1	16100	化油器总成	Carburetor Assy	1	

E-14 电器 Electric Elements

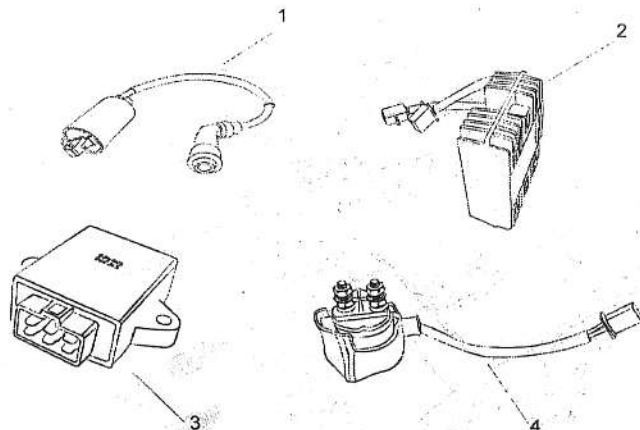

序号 S/N	零部件代号 Part No.	零部件名称	Description	数量 Quantity	备注 Remark
1	34500/172FMM	点火线圈	Coil, ignition	1	
2	31600/172FMM	电压调节器	Rectifier	1	
3	34400/172FMM	点火控制器	Controller, ignition	1	
4	34600/1P52QMI	起动机继电器	Relay, starting	1	

E-15 倒档箱总成 Case Assy, Reverse Gear

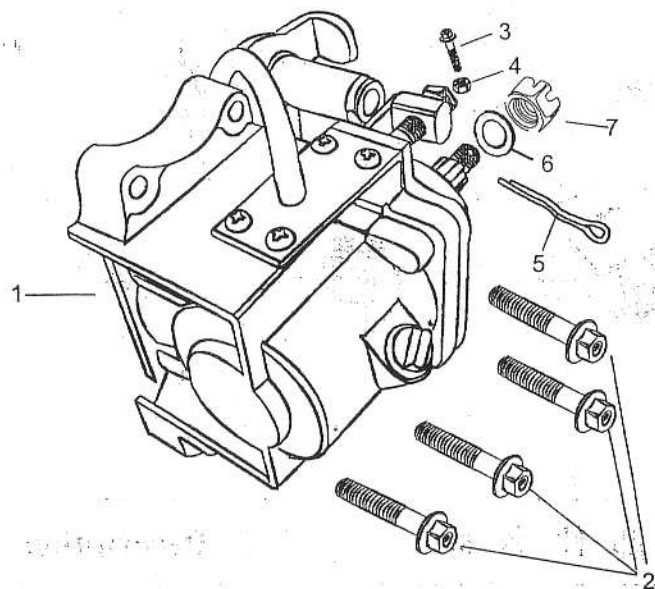

序号 S/N	零部件代号 Part No.	零部件名称	Description	数量 Quantity	备注 Remark
1	23900	倒档箱总成	Case Assy, reverse gear	1	
2	GB/T5781	螺栓 M8×40	Bolt, M8×40	4	
3	GB/T5783	螺栓 M6×30	Bolt, M6×30	1	
4	GB/T41	六角螺母 C 级 M6	Nut, hex, M6	1	
5	GB/T91	销 3.2×40	Pin, 3.2×40	1	
6	GB/T95	平垫圈 C 级 12	Washer, flat, level 12	1	
7	GB/T6181	螺母 M12	Nut, M12	1	

E-16 散热器总成 RADIATOR ASSY

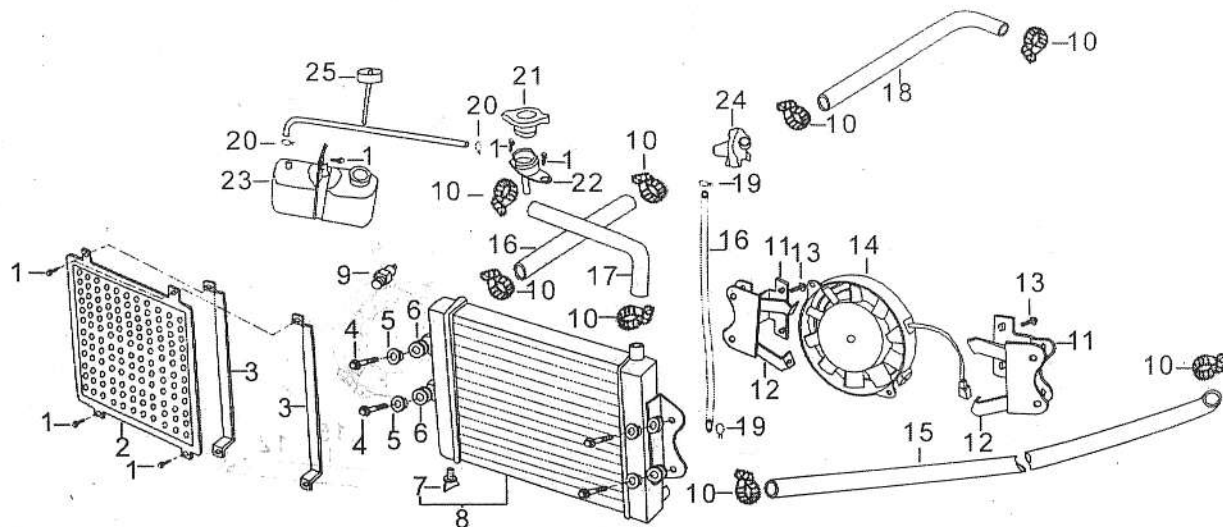

序号 S/N	零部件代号 Part No.	零部件名称	Description	数量 Quantity	备注 Remark
1	GB/T16674.1	螺栓 M6×12	Bolt, M6×12	7	
2	19440	散热器组合网罩	Hood	1	
3	19444	网罩连接支架组件	Stay	2	
4	GB/T16674.1	螺栓 M6×30	Bolt, M6×30	4	
5	93551	翻边垫圈 I	Washer, I	4	
6	19485	支架减振套	Rubber ring, radiator	4	
7	19493	散热器放水螺塞	Plug, radiator drain	1	
8	19410	散热器组件	Radiator comp.	1	
9	19980	风扇开关组合	Switch, fan	1	
10	18371	连接抱箍	Clamp	8	
11	19450	散热器支架组合	Bracket, radiator comp.	2	
12	19820	风扇支架组合	Bracket comp., fan	2	
13	GB/T16674.1	螺栓 M8×16	Bolt, M8×16	4	
14	19800	风扇总成	Fan Assy	1	
15	19615	散热器出水管	Hose comp., radiator outlet	1	

E-16 散热器总成 RADIATOR

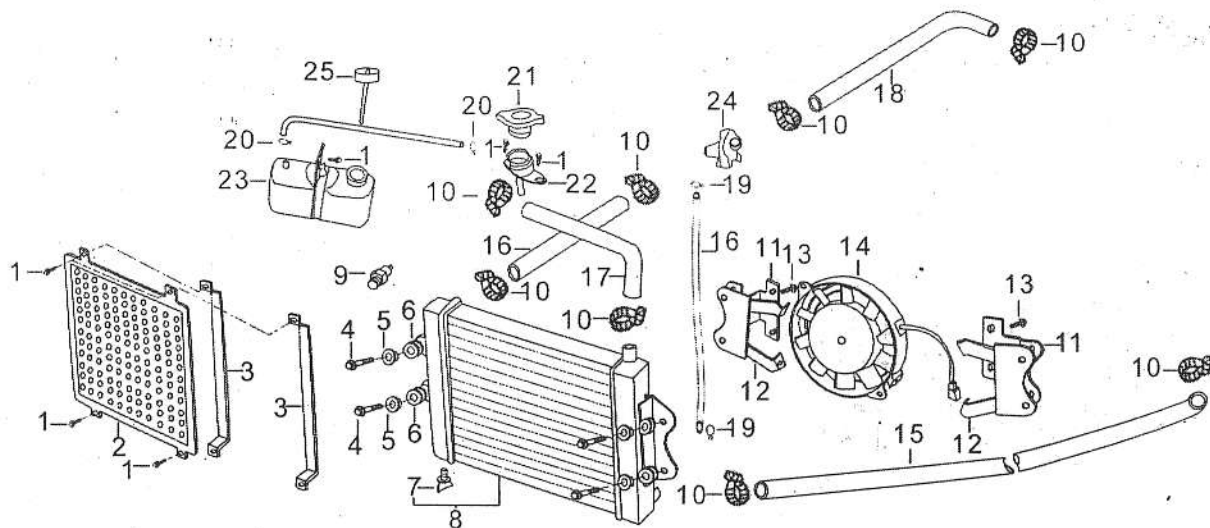

序号 S/N	零部件代号 Part No.	零部件名称	Description	数量 Quantity	备注 Remark
16	19363	节温器小水管	Hose, thermostat	1	
17	19614	散热器进水管	Hose, radiator inlet	1	
18	19365	节温器进水管	Hose, thermostat inlet	1	
19	19362/150-17	节温器小水管环箍	Circlip, thermostat hose	2	
20	19141/150-17	贮备水箱出水管环箍	Band, reserve tank	2	
21	19560	水箱盖总成	Cap comp., radiator	1	
22	19677	冷却液加液口	Opening, filler	1	
23	19100	贮备水箱	Tank, reserve	1	
24	19300	节温器总成	Thermostat	1	
25	19110	贮备水箱盖组件	Cap comp., reserve tank	1	