



LF125T-6

MOTORCYCLE OWNER'S MANUAL



CAUTION

Do not touch the exhaust pipe within 10 minutes after stopping the engine, for it is very hot.
Please park away from dry lawn or inflammable articles.
The brake shoe will be wet while cleaning the scooter. Check before riding.

Loading

The handlebar is difficult to handle after loading. Be careful! Operation of an overloaded scooter could easily cause the handlebar to swing.

Therefore, never overload your scooter. The loading weight on the carrier should not exceed 5 kg, on the tool compartment, 1 kg, and the storage compartment, 10 kg.

Securely fasten the goods on the carrier with strong ropes. The loose packing will influence the stability of the scooter and your attention to the road.

Put objects in the rear box and fasten it on the carrier if there is one.

CAUTION

Operate according to the manual.
Observe traffic regulations and ride carefully.

2. Description



3



4

3. Number Location

Vehicle Identification Number (VIN) and engine serial number are not only used for registration, but also used as the warranty for maintenance.

The number location is shown as arrowhead A, B and C indicate:

A, C indicates:

Vehicle Identification Number (VIN):

B indicates:

Engine serial number:



5

4. Control functions

Meters

1 Speedometer

The speedometer registers miles per hour of forward speed.

2 Odometer

The odometer registers the number of kilometers the vehicle had traveled. The unit of last digit is hundred meters.

3 High beam indicator light

This indicator light comes on when the high beam is used.

4 Turn signal indicator light

When the turn signal switch is used, the corresponding turn signal indicator light and turn signal light come on simultaneously.

5 Fuel gauge

The gauge shows the remained fuel in fuel tank

(when the ignition switch is on "O" position, the hand of the fuel gauge returns to zero.) When the hand is within the red area, it means there is still 1 liter of fuel in the tank. Please fill gasoline as earlier as possible.

6 Voltage indicator light

When the voltage of the voltage indicator light reduces to 10.8 ± 0.2 V, it will come on to warn you to recharge.

6

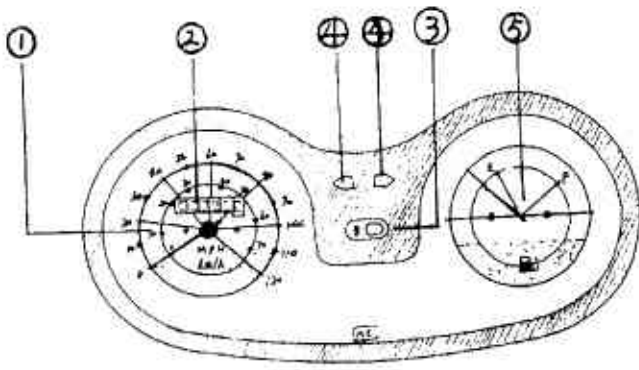

Ignition switch

- ⊗ In this position, all circuits are switched off. The engine cannot start.
- In this position, electrical circuits are switched on. The engine can start. The key cannot be removed.
- 🔒 In this position, the handlebar is locked. (See page 11.)

CAUTION

Always lock the handlebar and remove the key when the scooter is unattended.

Electric starter switch



To use the electric starter switch, turn the ignition switch to "○". Squeeze the brake lever or press down the brake pedal firmly. Push this switch, and the starter motor runs.



The engine is started. (For more information, please read page 13.)



Engine stop switch

Turn the ignition switch to "○"

RUN: In this position, ignition circuits are switched on. The engine can start.

OFF: In this position, ignition circuits are switched off. The engine cannot start.

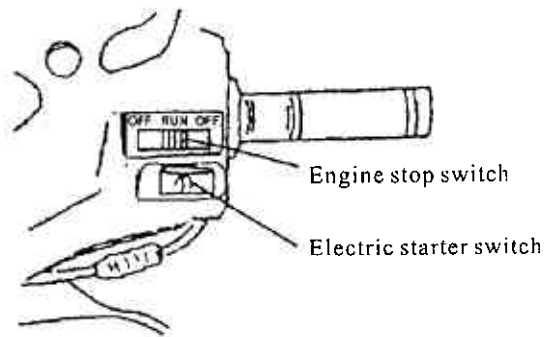

Dimmer switch

Turn the ignition switch to "O"

 The high beam light comes on.

 The low beam light comes on. When riding in urban or meeting with vehicles coming from the front, turn on this light to avoid affecting others' view.

9

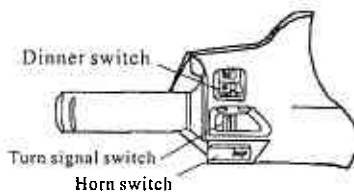

Horn switch

Turn on the ignition switch to "O". Press the horn switch to sound the horn.

Turn signal switch

While turning or changing the lane, use the turn signal switch. Push the switch left or right, the front or rear turn signal light and the turn signal indicator light will flash accordingly.

: Signal a left-hand turn.

: Signal a right-hand turn.

To stop the lights from flashing, push the switch in.

CAUTION

The turn signal light cannot go off automatically. It should be turned off after using. Otherwise it will affect other driver's safety.

When the ignition switch is at "⊗", the turn signal light will not operate.

Storage compartment

The storage compartment is located under the seat.

Storage compartment

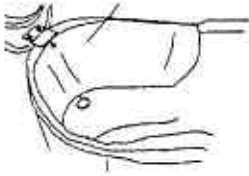

CAUTION

The loading weight in the storage compartment should not exceed 10 kg.

Do not put objects or food that cannot stand for high temperature, or flammable material into the compartment, for the engine is very high at temperature.

Do not put precious articles into the compartment.

Do not let water enter the compartment while washing the scooter.

Handlebar locking

To prevent theft of your scooter, always lock handlebar when parking.

How to lock

Turn the handlebar all the way to the left. While pushing the key into the ignition switch, turn it from “⊗” to “⊔” and remove it. Thus, the handlebar is locked.

How to open the lock

To release the lock, turn the key to “⊗”, and the handlebar can move.

11

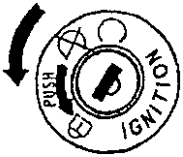

CAUTION

After locking, turn the handlebar lightly to make sure it is locked.

Never turn the key to “⊔” while the scooter is moving. This will result in loss of control or an accident.

Do not park the scooter on the place blocking traffic.

Tool compartment

How to open

To open the tool compartment, put the key into the hole and turn clockwise.

How to lock

Turn clockwise after putting in the key, and close the cover. Turn counter clockwise to lock the tool compartment.

CAUTION

The loading weight in the tool compartment should not exceed 1.0 kg.

Do not put precious objects in the tool compartment.

Water may enter the tool compartment when washing the scooter. Take care of the inside objects.

12

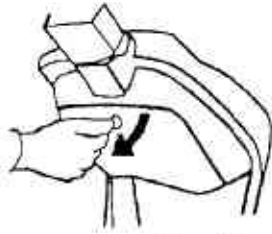

How to open

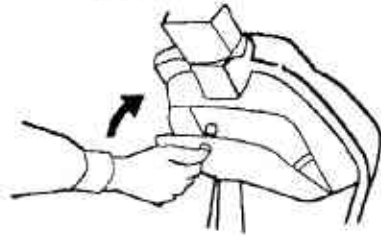

How to close

Use the key to open or close the tool compartment.

How to start the engine

Before starting the engine, make sure the engine oil and fuel are enough.

To start the engine, retract toe center stand.

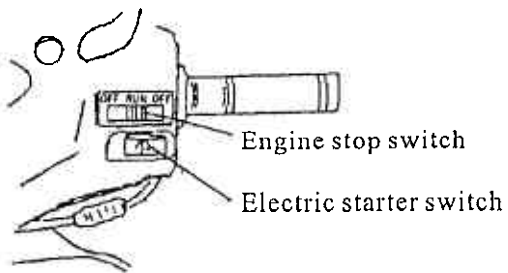

Turn the ignition switch to "O".

Turn the engine stop switch to "RUN"



CAUTION

When the key turns to "O", the horn and turn signal lights can operate.

Electric start

Squeeze the brake lever or press down the brake pedal firmly. Push the electric starter switch to the engine.

CAUTION

Do not operate the electric starter continuously for more than 5 seconds. Wait at least 10 seconds between each operation of the starter.

Release the electric starter switch at once after starting the engine. Never operate the electric starter when the engine is running, or it will cause damage to the starter motor.

To operate the electric starter, squeeze the brake lever or press down the brake pedal firmly. Otherwise, the electrical circuits are off and the starter motor does not work.

Kick start

Open the throttle a little bit and step on the kick lever forcefully. The engine will be started.

CAUTION

After starting the engine, release the kick lever for safety, or the engine can be damaged.

The exhaust fumes contain carbon monoxide that is harmful to human body. Never start your motor in a place ventilated poorly or closed area.

5. Operation**Riding off**

Brake the rear brake pedal, then push the scooter forward, the central stand will rebound automatically.

Straddle the scooter from the left side with your left foot on the ground to prevent slipping down,

Open the throttle slowly while releasing the brake. The scooter will start to move.

CAUTION

Before riding, apply the rear brake to avoid rushing out.

Before riding, please don't open the throttle at will, to avoid the scooter rushing, causing accident.

15

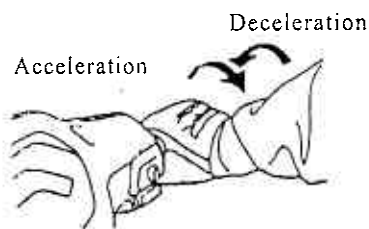
**CAUTION**

Do not open the throttle greatly because the scooter will rush out abruptly.

Correct riding

Before riding, turn on the turn signal light. Make sure there is no vehicle coming from the back, then start to ride.

CAUTION

See page 1 to page 3 for Notes for safety.

Strictly observe the break-in requirements (see page 24) for a new scooter and avoid riding at sudden acceleration.

After the break-in period, gradually increase the speed to its highest. Remember not riding at high speed for a long time, or it will cause danger and shorten the service life of the engine.

The speed adjustment is controlled by the throttle grip.

Increase the throttle Accelerate

 Open the throttle slowly.

 Opening the throttle gradually at the beginning or during climbing the hill.

Decrease the throttle Decelerate.

16

How to park

Near parking lot

Turn on the turn signal light. Stop the scooter after making sure no vehicle is coming from the back. Release the throttle grip, and apply brake slowly. The brake light will come on to warn the back vehicles.

After firmly parking

Turn off the turn signal light, and turn the ignition switch to "



Get off the scooter from the lift, and push the scooter to a level surface where is not blocking the traffic. Hold the handlebar with left hand, and the lower groove of the seat with right hand. Stop down the center stand with right foot. Put back with right hand forcefully, and the center stand will be up.

CAUTION

Please park away from dry lawn or inflammable articles.

Do not touch the exhaust pipe within 10 minutes after stopping the engine, for it is very hot.

17

6. Inspection before riding

Check fuel

Check the fuel gauge when the ignition switch is in "O" position. When the needle is within the red area, about 1.0 L fuel remains in the fuel tank, Please fill the fuel tank with #90 or #93 gasoline as soon as possible.

Insert the key to open the seat and open the fuel tank cap by turning it 1/4 circle clockwise.

Turn counter clockwise to its original place to lock the cap, then lock the seat.

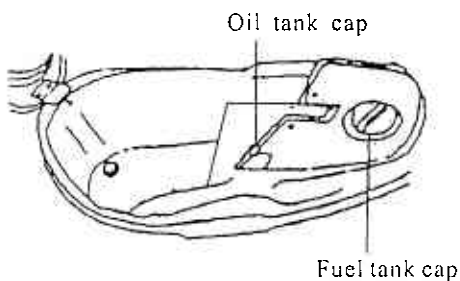

CAUTION

Stop the engine when refilling. Avoid fuel dropping on the heating engine.

Turn slowly when opening the fuel tank cap.

The fuel tank capacity is about 7.8 liters.

18

Check engine oil

Place the scooter with the center stand up on a level surface. Remove the dipstick to wipe it clean, then put it into the engine oil inlet (don't need to turn it). Take out the dipstick. When the level nearly reach the lower limit, please add the engine oil until it reaches the upper limit. The oil tank capacity is about 0.9 liter.

Please use SF 10w/30 or SF 15w/40 four-stroke special 4-stroke oil.



The engine oil dipstick

Upper limit Lower limit

CAUTION

If the scooter is tilted or just stopping, it can lead to false readings on the meter.

After the engine is stopped, beware of being scalded if you check the oil level or refuel at once.

Please use the specified 4-stroke engine oil. Do not mixed with other oil.

Check brakes

The brake lever or pedal should have an adequate free play (as shown).

19

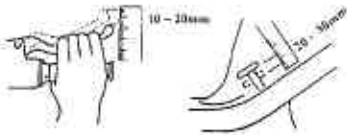

Squeeze the brake lever or press down the brake pedal firmly. A soft, spongy feeling in the brake lever indicates the adjusting nut should be adjusted. If the adjustment produces no effect, the brake system is faulty. Please go the repair station for maintenance.

Check the front brake

Squeeze firmly the front brake lever for several minutes to check if brake fluid leaks form the brake pipe connector or master cylinder.

If leaking, go to the repair station to check the front brake system.

Squeeze firmly the front brake lever to check the brake calipers. If the calipers have worn to reach the bottom of the slot, replace them with new ones.

Check the brake fluid in the front brake master cylinder for sufficiency through the observation window. If the level is lower than the LOWER mark, refill the DOT-brake fluid.

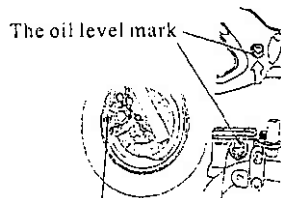

Connector of the brake pipes.

Check the rear brake

Press down the rear brake pedal.

When the rear brake shoe wear indicator folds with the arrow on the engine, replace the rear brake shoe.

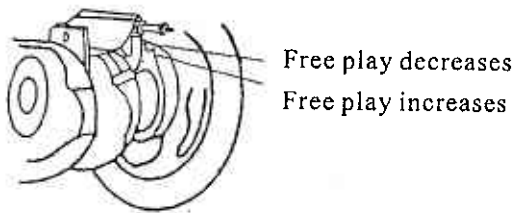

Adjust the rear brake

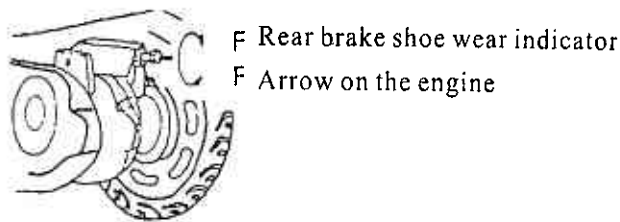

21

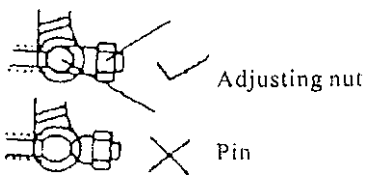

CAUTION Turn the adjusting nut clockwise or counter clockwise to reach the appointed brake pedal free play. After adjustment, aim the slot of the adjusting nut at the pin to avoid possible danger while riding.

Check tires

Check the air pressure of the front and rear tires frequently because the improper pressure will cause abnormal tread wear and cracks, resulting in danger while riding.

	Standard tire pressure	Size of the tire
Front wheel	204kpa	3.50-10 4PR
Rear wheel	230kPa	3.50-10 4PR

When the tread depth of front and rear tires are below 1.6 mm, replace the front and rear tires. The excessively worn tires will result in unstable handling, causing accidents because of loss of control.

When the tires have cracks and scratches, replace them with new ones.

Check lights

Turn on the ignition switch to "O" position:

Turn on the turn signal switch. Check if the front and rear turn signal lights flash simultaneously.

Apply the front and rear brakes to check if the brake lights come on.

Turn the ignition switch to "O" to check if the city lights, meter light, headlight, and license light come on, and if the dimmer switch operates normally.

Check handlebar

Shake the handlebar up and down, forward and backward, left and right to check for slack.

Turn left and right to check for free movement and blocking case.

Put the front wheel straight forward to check the handlebar for deflection.

Check speedometer and horn

Turn on the ignition switch to "O" position:

Push the horn switch to check if the horn sounds and if the sound is normal.

Ride at low speed to check if the needle of the meters turns normally.

Check front and rear shock absorbers

Press the handlebar and the seat, then bounce up and down to check the front and rear shock absorbers for good operation.

Check rear view mirror and license plate

Sit astride the seat to check if the angle of the rear view mirror is proper.

Check the license plate for damage or slack.

23

Other checks

Check if the muffler is loose, and the sound is normal.

Check if the previous abnormal cases still exist.

7. Break-in operation

The first 1500km that the motorcycle is ridden is designated as the break-in period. If the motorcycle is not used carefully during this period, you may very well end up with a "broken down" instead of a "broken in" motorcycle after a few thousand kilometers.

The following rules should be observed during the break-in period.

Mileage (km)	Speed(MPH)
0-500	<15
500-1000	<22
1000-1500	<30

CAUTION

Please strictly observe the break-in requirements while riding a new scooter.

Avoid riding at constant speed for long period of time during the break-in period.

8. Periodical maintenance

To prolong the service life of your scooter, please make periodical inspection and maintenance of the scooter according to Periodical Maintenance Chart. If your scooter is often ridden on poor roads, alter this time schedule of some items to shorter intervals in order to ensure the reliability of the scooter.

CAUTION

After a new scooter has been ridden its first 500km or for the first month, check and service the scooter.

A careful check of certain equipment must be made after periods of storage.

24

Items	Odometer reading (km)													
	300	1000	2000	3000	4000	5000	6000	7000	8000	9000	10000	11000	12000	Daily safety check
Engine oil														
Oil screener *	C			C				C					C	
Gear oil *	R					R					R			
Spark plug	clean every 2000km, and replace with a new one if necessary													
Air cleaner	Clean the filter element every 1000km, and replace with a new one if necessary													
Clearance of valve *		A			A			A					A	
Cam chain *		A			A			A					A	
Carburetor *					I			I					I	
Fuel screener *						I					R			
Braking system		I	I	I	I	I	I	I	I	I	I	I	I	I
Driving chain *		I		I		I		I		I		I		
Driving belt *														
Screws, nuts	T					T					T			
Cable lubrication														
Oil pump	I	I	I	I				I			I			
Carbon on cylinder and piston				C				C			C			C
Starter motor, Generator *											I			

Note: Go to a repair station to service the items marked with an "*". Clean air cleaner
Dust deposit is the main cause of engine power reduction and fuel consumption increase. Clean or replace regularly according to the periodical maintenance chart.

How to clean

For foam plastic filter element

Put the outer foam plastic filter element into non-flammable solution (such as soap water). Clean off the dust and foreign materials. After cleaning, squeeze the element dry. Do not twist it. Soak it in the 4-stroke engine oil and squeeze it.

For paper filter element

Pat the paper filter element slightly to drop off the dust through shaking, or brush away the dust on the surface and in the slots of the element with soft brush.

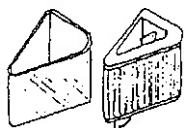

CAUTION

While washing, do not deform the filter element.

Never wash the paper filter element with water or fuel as detergent.

Replace the filter element if too dirty or damage.

Please clean and replace the filter element in accordance with the time or mileage schedule.

To assemble the air cleaner, if the cover or the filter element cannot be installed to their original position, the dust will be directly absorbed into the cylinder, which will cause wearing. The horsepower will reduce and the life of the engine will be affected.

While washing, do not let water enter the air cleaner to avoid abnormal start.

If it is often ridden on a hard dusty road, or if the fuel consumption increases obviously, please clean or replace the filter element at once.

Maintenance and replace battery

To ensure the battery is often in the best condition, the scooter adopts an auto rapid charging system.

Turn the ignition switch to "0" before replacing the battery.

Make sure the +/- terminals of the new battery are correctly connected with the red and "-" terminal with the black lead.

When the scooter is not used for a period of time, remove the battery and store it in a cool, dark place. Completely recharge the battery before reinstallation.

Replace fuse

Turn the ignition switch to "⊗"

The fuse can be seen in the fuse box near the battery.

Open the fuse box, and tighten the fuse box after replacement.

The specified fuse is 15A

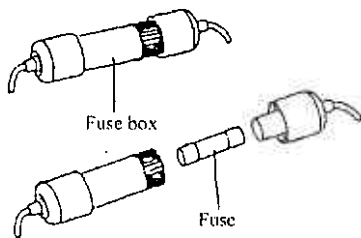

CAUTION Inspect the cause of the burnt fuse and replace it.

Do not use fuse of other size except the specified one.

27

Check spark plug

The spark plug trouble is one of the cause of the difficulties for starting the engine. Excessive electrode erosion and electrode gap will make the sparking incomplete.

Remove the spark plug with special spark plug wrench,

Check if the spark plug seat and electrode have greasy dirt, and if the electrode has carbon deposit and burnt. Greasy dirt and carb on should be cleaned immediately if found (with spark plug cleaner or needle brush). If the spark plug accumulates much carbon and burns seriously, or the insulator cracks or comes off, replace it immediately.

Check the electrode gap of spark plug. Adjust the gap to the specified value if needed. If it is unable to adjust, replace it.

Screw the spark plug in first with your hand, then tighten it with special spark plug wrench.

The specified spark Plug:

(NGK) C7HSA; A7TC

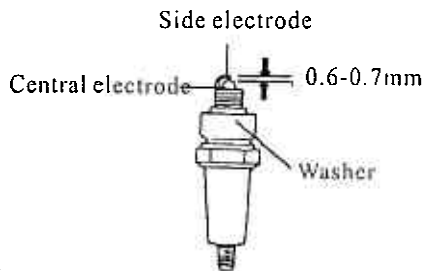

CAUTION

The working temperature of the engine is very high, beware of being scalded.

Do not use the spark plug of other model except the specified one.

28

When the scooter is not used for a period of time, remove the battery and store it in a cool, dark place. Completely recharge the battery before reinstallation.

Replace fuse

Turn the ignition switch to "⊗"

The fuse can be seen in the fuse box near the battery.

Open the fuse box, and tighten the fuse box after replacement.

The specified fuse is 15A

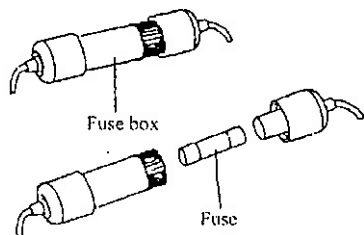

CAUTION Inspect the cause of the burnt fuse and replace it. Do not use fuse of other size except the specified one.

27

Check spark plug

The spark plug trouble is one of the cause of the difficulties for starting the engine. Excessive electrode erosion and electrode gap will make the sparking incomplete.

Remove the spark plug with special spark plug wrench,

Check if the spark plug seat and electrode have greasy dirt, and if the electrode has carbon deposit and burnt. Greasy dirt and carb on should be cleaned immediately if found (with spark plug cleaner or needle brush). If the spark plug accumulates much carbon and burns seriously, or the insulator cracks or comes off, replace it immediately.

Check the electrode gap of spark plug. Adjust the gap to the specified value if needed. If it is unable to adjust, replace it.

Screw the spark plug in first with your hand, then tighten it with special spark plug wrench.

The specified spark Plug:

(NGK) C7HSA; A7TC

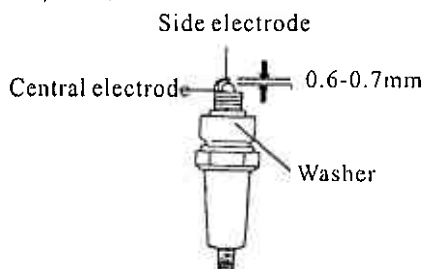

CAUTION

The working temperature of the engine is very high, beware of being scalded.

Do not use the spark plug of other model except the specified one.

28

Replace engine oil

Replace the engine oil after the first 300km. From then on, replace it every 1000km. Check the oil level every 500 km. If insufficient, add the specified engine oil.

Place the scooter on the center stand on a level surface. Warm up the engine for about 5 minute, then remove the dipstick and drain screw. Take out the oil strainer and drain the engine oil.

Install the oil strainer after cleaning. Wipe the drain screw clean and reinstall it by tightening.

Fill the specified 4-stroke engine oil (see page 19). The amount of the engine oil is about 0.9L.

Insert and fasten the dipstick.

Warm up the engine, then stop it for 10 to 20 seconds. Check the oil level with the dipstick to ensure the oil level is above the specified upper limit. (See page 19 for how to check.)

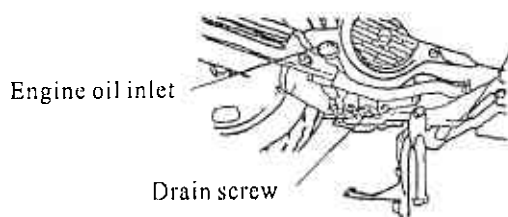

CAUTION Please use the specified four-stroke engine oil. Do not use other grade engine oil or deteriorated oil or mixed engine oil.

If you operate your scooter on the crushed stone road, for short distance, in cold area, or if it idles for a longer time, replace the engine oil ahead of time schedule.

While refilling, do not exceed the upper limit of the dipstick.

When warming up the engine to replace the engine oil. Beware of scalded.

Replace gear oil

Replace the gear oil after the first 300km. From then on, replace it every 5000km or six months. Please use the specified gear oil-85w/90 Sh0350.

Place the scooter on the center stand on a level surface, warm up the engine for about 3 minutes and stop it.

Screw off filling screw (filler cap) and drain screw to exhaust the original gear oil.

Fasten the drain bolt after cleaning. Refill the new specified gear oil about 110 ml from the inlet hole.

Install and tighten the filling screw (filler cap).

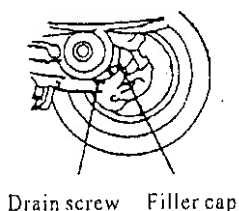

CAUTION

If you often operate your scooter in rains, for long distance and with excessive load, you should shorten the mileage and time of replacement.

Please use the specified gear oil. Do not use other gear oil or deteriorated oil or mixed gear oil.

Tighten the drain screw and filling screw (filler cap). Be careful of oil leak.

Beware of scaled during oil replacement.

Idle speed adjustment

To adjust the idle speed, put up the center stand to raise the rear wheel off the ground.

After the engine is started, preheat it for 2-3 minutes.

Loosen or tighten the adjusting screw A to adjust the idle speed at 1700±100r/min.

31

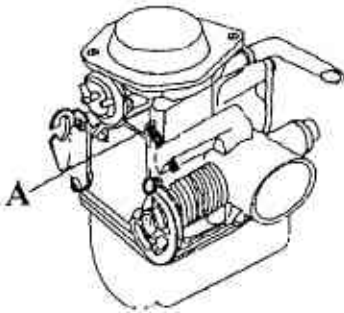

CAUTION

Turn "A" counter clockwise, the idle speed will reduce, or vice versa, increase.

The idle speed adjusting screw has already been adjusted to the best status before ex-factory. Do not adjust it.

General lubrication

Visually check if all lubrication points of the scooter body are well lubricated (see page 26 for details).

- | | | |
|---------------------------------------|-----------------------------|--------------------------------------|
| 1. Engine stop switch | 2. Generator | 3. Regulator/Rectifier |
| 4. Enricher | 5. Igniter | 6. Spark plug |
| 7. Ignition coil | 8. Fuse | 9. Ignition switch |
| 10. Battery | 11. Starter relay | 12. Starter motor |
| 13. Electric starter switch | 14. Horn switch | 15. Turn signal switch |
| 16. Flasher | 17. Voltage sensor | 18. Fuel gauge |
| 19. Front brake light switch | 20. Rear brake light switch | |
| 21. Dimmer switch | 22. Horn | |
| 23. Front left turn signal light | | 24. Rear right turn signal light |
| 25. Right turn signal indicator light | | 26. Left turn signal indicator light |
| 27. Rear left turn signal light | | |
| 28. Front left turn signal light | | |
| 29. Voltage indicator light | | |
| 30. Fuel sensor | | |
| 31. Brake/tail light | | |
| 32. Meter light | | |
| 33. City light | | |
| 34. Headlight | | |
| 35. High beam indicator light | | |

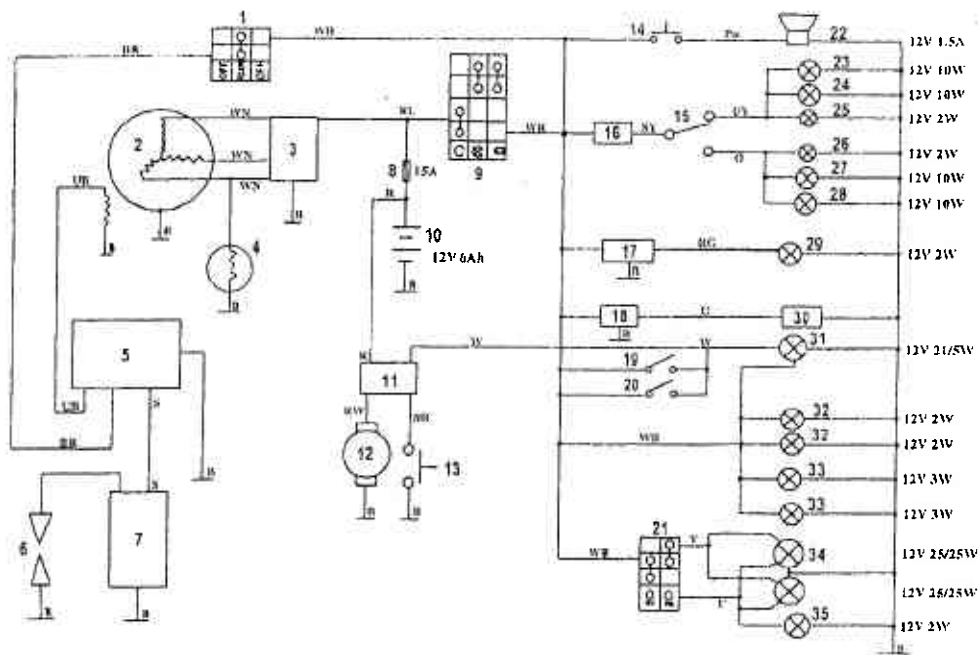

Color	Red	Yellow	White	Black	Brown	Green	Blue	Grey	Orange	Pink	Purple
Code	R	Y	W	B	N	G	U	S	O	P	Pu